

# You Teach, Why do Students not Learn? Part I

Try this experiment for yourself. Go ask a number of adults “What is the meaning of pi?”. The majority of them will have actually used the value when they were in school but, years later they won’t remember much about it. Is this just because they haven’t used the value since leaving school or is it also because of the way they were taught? The question of why we teach material that 99% of the students will never use is a topic for another article.

Present teaching methods based on the presentation (lecture) approach give the appearance of efficiency because the presenter covers a large amount of material. If the evaluation is then based on the return of key points of that information by the student, the method appears to work. But for the vast majority of students, this process is a complete waste of time. Ask them about any of those points 9 months to a year later and you’ll find that they remember few if any. Try that 10 years later and they probably won’t even remember taking the course or if they do remember, it will be because it was so painful.

If the lecture method is bad, why do we continue to use it? There are many reasons. It is an absolute truth that “All teachers start out teaching as they were taught”. In other words, we use the same methods and techniques that were used on us when we were in school. Another very common reason is some teachers absolutely have to be the center of attention. They love to lecture and show off their knowledge. For many, the process inflates their personal ego. Some people call this the “I’ve got a secret” method of instruction and the student has to figure out what the secret is.

In every ATech/AIPC workshop I ask this question of the participants, “What would you think if I had given you a 20 page reading assignment and a 2 page question and answer sheet as your first assignment when you came in this morning? Would that excite you? Would you want to do that? **Why do we do that to students?**” The same idea applies to lectures. While you may think you are the world’s most entertaining lecturer, it is guaranteed that your students don’t. Would you enjoy sitting there, totally inactive, while someone puts point after point on a whiteboard or projects them with PowerPoint?

I call what normally happens to the student, **PowerPoint Paralysis**. Their eyes glaze over, their brain goes to sleep, and their legs and butt become numb. Most teachers accept this and as long as the student’s eyes don’t close, this would be deemed a successful learning experience for the student.

How do you change your program? It will be a gradual process - one program section or module at a time and it will take considerable work on your part. Student involvement is the key and “hands on” and “discovery” are the techniques to use. Let’s take the pi experiment as an example. One way to incorporate both “hands on” and “discovery” would be to give a student several round items, ex. a piece of plywood cut from a 3/4 inch thick sheet with a hole saw, a soda can, a ring from a fruit jar, etc., and a cloth measuring tape. Tell them that all of these items have some things in common.

One is they are round, what’s another? Obviously, the cloth measuring tape is a hint. At this point, if a student came up with the answer that it is the ratio of circumference to diameter (pi), you would be amazed. But as your students become more attuned to the “discovery” process, they will get better. For the most part, they have never had to discover something for themselves in the educational process and should not be expected to automatically pick it up. If they didn’t know in all other classes, they asked and the teacher gave them the answer.

How do you help them adjust to discovering things? Never answer a question except with a question. Ask them the question they should have asked themselves. In our example of pi, some of the students will be completely lost. Ask them “How many different dimensions can we measure on these objects?”. Let them work with that question for some time. They must be given the opportunity to think. What’s the next question? How about “Are any of the ratios the same?”

It is much easier and quicker to tell them pi is the number which represents the ratio of a circle’s diameter to its circumference. But for understanding to take place, they must discover this individually. Then they own it and will probably never forget it. As a teacher, this is the most difficult way to teach because you must plan each learning experience in detail but to ensure student understanding, it is the only way to teach.

Remember “**The key to a successful program is to put yourself in the place of the student.**” If you wouldn’t like performing a particular activity, why do you think the student will? Does the Education process have to be painful?



*Fred Hines*

# You Teach, Why do Students not Learn? Part II

Try this one question evaluation of the applied academics of your program. "If each of the four wheels supporting a 4000 pound vehicle is inflated to 30 pounds of air pressure, how can they support the weight of the vehicle?" Give this question to your students and see how many give you the correct explanation.



ATech used the question on a pre-employment exam for a few years. We had less than 5% answer the question correctly and there was no correlation as to the level of education they had completed - high school, post-secondary, vo-tech, associate degree, or four year degree.

One of the most critical points in building a successful "discovery" activity is to ensure that the student has the necessary tools/understanding to perform the activity. In the tire pressure example, the automotive teachers of our potential employees would all have guaranteed that their students could answer that question but it had been missed in the education/training process.

From the last Newsletter article about pi, what if the student could not read a measuring tape? A truly innovative student would probably just make marks on the tape, transfer the distances to a piece of paper, and then make a relative comparison of the lengths. You would be amazed if you had a student that was that creative, wouldn't you? But they are out there. Most are just too embarrassed because of the failures of some previous teachers. It is easier to act as if they have no idea.

For those teachers who, for whatever the reason, can not give up their lecture sessions, there is "Directed Group Discovery". While not as effective as individual Discovery, it is much better than the standard lecture approach. "Directed Group Discovery" will work with any size group but it is easier to keep everyone involved with smaller groups (5 - 10). Remember, "Discovery" is about asking questions, make as few statements as possible.

High school physics is one of the most difficult and feared subjects in the entire high school experience, right? Why? Because of how it is taught. Physics is a subject that every person of high school age has a wealth of understanding from their life experiences. What do new automotive technology students already know about automotive technology? There are hundreds of laws from basic physics they understand. For example, ask the class to show how they warm their hands on a cold winter day. They will all exhale (open mouth) into the

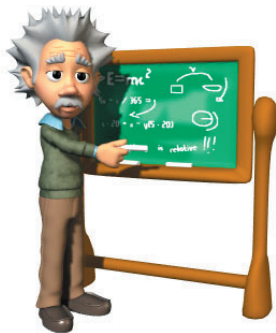

hands. Now ask them to demonstrate how they cool a spoonful of hot soup. They will pucker their lips and blow. They know that increasing the pressure of hot air (approximately 85 - 90 degrees from their body), forcing it through a restriction (their lips) makes it cooler when it strikes an object. They can feel the effect on their hands! Does this bring any automotive applications to mind? How about an a/c orifice and Bournelli's Laws? They already understand one of Bournelli's Laws! This "teachin" stuff is too easy!



This is a great place to add an item to the student's "never forget" memory. Ask the class why they sweat during physical exertion. "It cools their body through evaporation of the moisture." The evaporator of the air conditioning system cools the surrounding air through evaporation of the refrigerant. Once you tie the evaporator to their body's sweating and cooling, they will never forget what the evaporator does.

Here is another great question for group discussion, "Why do hot-air hand dryers always feel cold when you initially place your wet hands in the air stream?" It doesn't matter if they have been operating for 10 minutes, they will still feel cold.

What other things do they understand? Inertia, momentum, acceleration, deceleration, pound per square inch, .... You add to the list. Those previous five items can all be brought into discussion by one simple in-class demonstration. Bring a hammer and two pieces of 2 x 4 with a spike nail started in each one to the class. Ask someone in the class to show how we can force the nail into the wood. When they start to swing the hammer, stop them and ask what they are doing?

Why don't they just set the hammer head on the nail? Why are they swinging the hammer? They know from experience that swinging the hammer makes it function as if it were heavier! The amount of weight needed to force the nail into the wood can be determined by placing weights on the nail until it starts to move into the wood, for example 50 pounds. Now, we have to determine why swinging the hammer makes a 16 ounce hammer appear to be the 50 pounds of weight needed to force the nail into the wood.

How do we determine the hammer velocity? Set a digital camera on 1/100 of a second, place a yardstick vertically in the background, and take some pictures of the hammer as someone drives the nail. Adjust the shutter speed as needed. Also take a picture that shows the hammer striking the nail. We need to determine a typical deceleration time - the time the hammer



## You Teach, Part II cont'd

meets the nail head until it stops as it drives the nail into the wood. The hammer smear in the picture against the yardstick will give a good indication of the velocity. This is better done before class as it may take a few pictures to get the ones you want to project. Have the class determine the velocity of the hammer head from the pictures.

We now have all the information we need to calculate the hammer's apparent weight gain. The energy level of the hammer is equal to its weight multiplied by its velocity. For example, 1 pound hammer head by 20 feet per second equals 20 pounds. But 20 pounds is not enough weight to force the nail into the wood as was determined previously. What is missing is the time of deceleration. Obviously it takes force to stop a moving object. The shorter the time, the greater the force. Multiply your deceleration time in secs by 32 and divide into the energy level. If our deceleration time is .01 second then  $20/(32 \times .01) = 62.5$  pounds. I have taken some liberties in our formula discussion but any basic physics textbook will give you the exact formulas you need. Is this a lot of work? Yes, the first time you prepare it but if you want to build on what they already know, it is required. Notice that this was a "Directed Group Discovery" process. We asked questions, performed measurements, and made observations. In short, we made the students active participants in the "Discovery" process. Teach this way and you can ask your graduates about the subject years later and they will still remember it. They own it, it wasn't just loaned to them until the exam! That is what "Structured Skill Development" and "Discovery" is all about.

Why did I bring two boards/nails to class? We do the same process with the other board/nail but find the weight to force the nail into the wood is many times greater, even though it is the same size nail and same type of wood? What could cause the difference? The two nails are pulled from the wood and we find that one has been blunted; the tapered end has been removed! The students already know that the tapered (sharpened) end makes it easier to drive the nail into the wood. The same reason we sharpen knives, right? This demonstration can lead to a lengthy discussion of pounds per square inch, apparent weight amplification, and women's high heel shoes. Women's High Heel Shoes?? It hasn't been too many years ago that some homeowners and public places that had soft tile or hardwood floors would not allow women with "stiletto" heels to walk on their floors. Why?

Once you start preparing and teaching this way, you will look forward to each school day. Why, because you know learning is taking place and that makes the job enjoyable.

Your assignment for the next newsletter is to think of the things your beginning students already know about electricity. Remember they need to be relevant to the subject. For example, students know what resistance is but do they know what electrical resistance is? I will use the best ones in the next newsletter. Email them to me at [newsletters@atechtraining.com](mailto:newsletters@atechtraining.com)

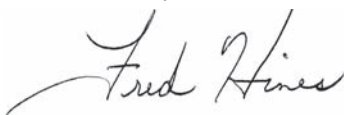

# You Teach, Why do Students not Learn? Part III

ATech has been involved in the electrical/electronics training programs of the major OEMs for the past 20 years. The vast majority of that involvement has been in designing and supplying the hardware for the programs; for example, the General Motors S.E.T. hardware. We have had very few opportunities to work with instructors as to presentation techniques, skill development, etc. During the entire 20 years there has been one constant refrain, "Our technicians cannot troubleshoot simple electrical problems". But yet, they always continue the same training processes and techniques while expecting different results. Recently a major OEM tested a large number of their dealership technicians and found that 40% could not troubleshoot a fault in a simple light bulb circuit! How can this be changed?



Equipment alone cannot solve the problem. While ATech has both software and hardware centered systems that emphasize troubleshooting techniques and practice, they cannot replace a knowledgeable instructor. If the instructor cannot troubleshoot the circuits and explain the troubleshooting process, satisfactory results will never be achieved. The OEM described above would probably have learned more if they had tested their instructors instead of the technicians. *Can you teach what you can not do?* Remember, the student isn't always at fault.

Why are good instructors so important to the learning process? Good instructors will analyze a student's questions and learning style and then modify the presentation to meet those needs. Sometimes just changing the wording of a question changes the student's comprehension level. Without the instructor, every student must adapt to the presentation style of a particular textbook, computer based or web based training program, etc.

ATech's 1800 series troubleshooting training system is in use in hundreds of training programs. Some OEMs and major industrial customers have limited its use because their instructors cannot troubleshoot the problems presented on the trainers. For example, one major fleet's instructors could not troubleshoot a high resistance in the ground path of a light bulb! Therefore the training program was simplified. A far better solution is to improve the instructor's skill level.

Another piece of the solution is in the high school and college level automotive programs using Structured

Skill Development and Discovery teaching techniques. In the first two articles of this series, problems related to geometry and physics have been used as illustrations. In this part, automotive electricity will be addressed. The last article closed with a question, "What do your new students already know about electricity?". Structured Skill Development requires that some common understanding of the subject be identified as a starting point to build on. In every group there will be one or two students who don't have this common level of understanding. They must be identified by the instructor and raised to the common level.

The most common form of direct current electricity and one that everyone has experienced has to be static electricity. This can be the starting point to explain how other forms of electricity are generated. For example, while static electricity is normally generated by mechanical friction, an automotive generator produces electricity by "magnetic friction". A magnetic field actually separates the electrons from the atoms in the same manner as mechanical friction. In either case, static or magnetic, motion is required to produce the separation. A battery generates electricity through chemical action. Acid acting on the metal parts of the battery separates the electrons from the atoms.

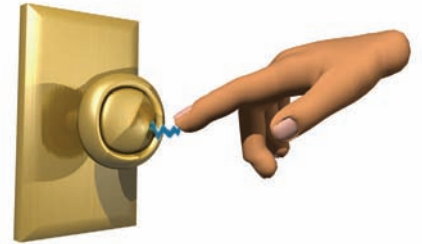

Depending on the amount of friction and weather conditions, static electricity can produce voltages in the 1,000s of volts range. An individual who is charged with static electricity will carry that charge until they come in close contact with another person or a metal object. When the distance between the two has been reduced to a gap that can be jumped by the amount of stored charge (voltage), an arc occurs. This arc is the current flow produced by the static voltage charge which equalizes the charge between the two. While the arc can



# You Teach, Part III, cont'd

cause minor pain, surprise is the primary reason for the sudden movement of the individual.

Batteries are probably the second most common form of a direct current source. Common batteries are 1.5 volts, 9 volts, and 12 volts. The term



“volts” is commonly used in the identification of a particular battery. Everyone has replaced 1.5 and/or 9 volt batteries in some electrical or electronic device. When they did so they had to observe the polarity of the battery or, in the case of 9 volt batteries, the connector could only

be connected one way. This is a key starting point to discuss the difference between direct current and alternating current. Most new students are also familiar with charging of batteries, primarily cell phone batteries.

What do new students know about normal alternating current supplied to their houses? They typically know it is 120 volts, light bulbs have wattage ratings, switches turn circuits on and off.

So far in this discussion, we have identified the following common knowledge elements concerning electricity that your new students possess:

1. A static electricity arc “hurts” because of current flow.
2. The ability of static electricity to jump a gap is dependent on the level of charge (voltage).
3. Batteries are rated by volts.
4. Batteries have a directional property (polarity).
5. Some batteries can be recharged.
6. House electricity is also rated in volts.
7. Light bulbs have power (wattage) ratings and that determines their light output.
8. Devices called switches control the circuits.



You can start your electrical section with Ohm's Law, series circuits, parallel circuits, math calculations, and lengthy lectures or you can take these identified common knowledge elements and build on them. If you were the student, which would you like?

*Fred Hines*

# You Teach, Why do Students not Learn? Part IV

I have included this email received from Stan Martineau in the series “You Teach, Why do Students not Learn” because it is a great example of what can happen when the concepts of Structured Skill Development are applied. Stan’s program at the College of Eastern Utah was also a National Runner Up in the AIPC Annual Awards of Excellence in Automotive Training. Congratulations to all of the National Winners, and Runners Up. Pictures are in the AIPC section of the Newsletter.



This year we purchased the ATech 3631 program to use as part of our electrical course. After basic electrical, meters and diagrams, we used the program to help teach a logical approach as part of the troubleshooting approach. Students were required to work on their own time and complete 12 random faults. That is where the “problems” with the program began - I would like to explain.

**Mistake #1** -- I only purchased two programs. Students would get on the ATech program and would not quit! I finally had to limit students to 45 minutes during class time and 2 hours after class. It took three days before all the students had their turn.

**Mistake #2** -- I did not specify which diagnostic procedure to use, some used the ohmmeter function while others used the voltmeter function which sparked lively debates about the benefits of each ---- Actually that turned out to be a good thing.

**Mistake #3** -- I used the ATech program as part of my hands on finals. Our advisory committee comes in to judge the lab portion, each judge knows the importance of telling each student the same information and to maintain consistency in scoring test results. As the day progressed I noticed a different judge at the ATech station, and later a third judge. I called a time out and asked the judges (local shop owners and technicians) if there was a problem --- It turns out that there was --- As one judge put it, “I have learned more about electrical troubleshooting procedures by watching students at this station than I have learned in the past several years” - The judges were so interested in the ATech station that they were trading stations just to watch the students and learn!

**Mistake #4** -- At the end of our testing I offered to teach a night class on multimeter use and troubleshooting procedures -- if they could fill the class. Guess what! I am now working to find time to offer the night class, you guessed it! Without any advertising, our local shop owners and technicians have filled the class. I have offered this class in the past and had a tough time recruiting enough students, what a change!

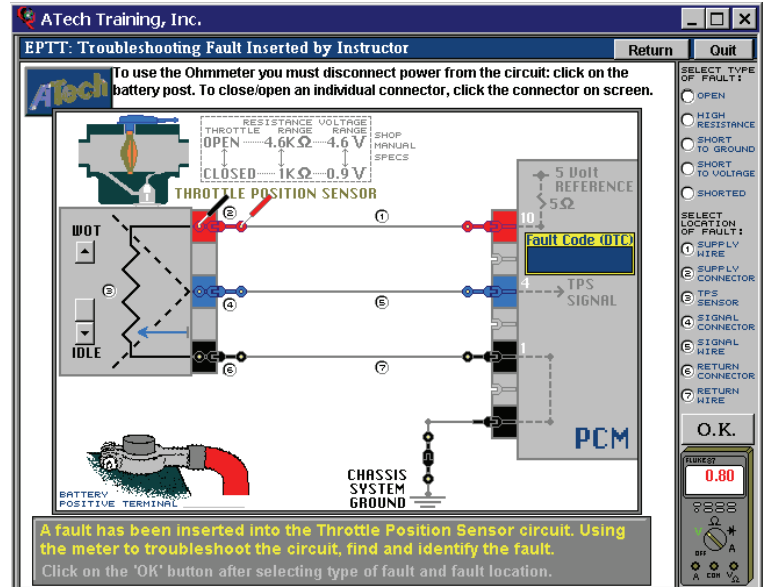

ATech 3631 operating in “Training Mode”

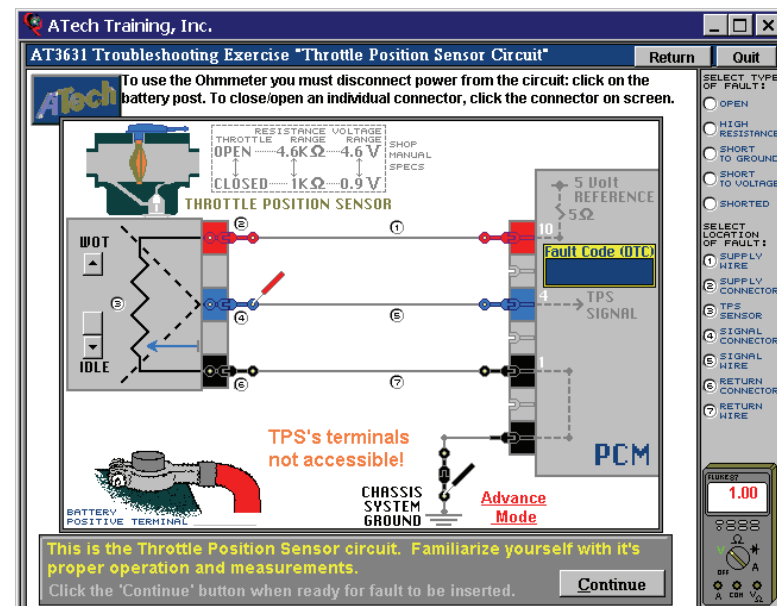

ATech 3631 operating in “Advanced Mode”

**Mistake #5** -- Would be the biggest mistake of all. It would be a BIG mistake to not add more training equipment from ATech. That is a mistake that I do not plan to make! Rest assured my friends that training equipment from ATech will be at the top of my priority list for next year!

Thank You for a great product  
Stan Martineau  
College of Eastern Utah

# You Teach, Why do Students not Learn? Part V

Teach experience. Sounds strange, doesn't it? All information, knowledge, and understanding comes from experience. Experience in the classroom, experience in the shop, experience in some form or other. In the academic world, experience is defined as being told information typically in the form of a lecture. In the automotive training program, experience is a combination of hands-on and classroom.

The sole purpose of education and/or training is to advance the "experience age" of the student. In other words, to create educational experiences for the student that without the teacher's help might require years of random experiences. For example, if someone tried to learn the effective use of a multimeter without any instruction, reading books, etc. it would probably take a long time, if ever. The teacher can create a group of learning experiences that guide the student to effectively use the multimeter in a much shorter time. The better the design of the learning experiences, the shorter the required experience time to reach the goal.

Everyone has met people who possess much more information, knowledge, and understanding about a particular subject than only their age would indicate. How did this happen? One factor is, they have been exposed to (experienced) many more learning events than other people. Many times they chose to participate in those events and, in some cases, have actually even caused them. How unusual is it to see an automotive technician who, on his/her own time, works with a scan tool and a vehicle to enhance their understanding? He/she is taking an active role in increasing their "experience age".

The amount of information, skill, and understanding that is required to service present day vehicles has expanded dramatically from that required only 20 years ago. Yet the amount of time allocated to teach the subject is essentially the same as it was in the 1980s. This is one of the most common

refrains about the NATEF task list; "We don't have time to teach all those tasks".

What does an instructor do? First, you must identify the skill level you need to teach. This is determined primarily by the level of your educational

program. If you are a secondary program, you should have a lower performance level goal than a post-secondary program. This is the major point of confusion concerning the NATEF standards and task list. No one including NATEF expects a secondary program to graduate a Master Technician. If you are

attempting that, you are doing a disservice to your students and your program. Remember, you can not teach brain surgery to a student who has not passed a course in anatomy.

Second, you have to become much more efficient in your teaching processes. NATEF has spent a tremendous amount of time in developing their Task Lists. Considering all of the problems and the scope of the project, they have done an excellent job. But, you must correctly interpret some of their statements. For example, let's take a task from the Brakes list:

Remove, clean, and inspect pads and retaining hardware; determine necessary action. The key phrase "**determine necessary action**" by NATEF definition means: "Indicates that the diagnostic routine (s) is the primary emphasis of a task. The student is required to perform the diagnostic steps and communicate the diagnostic outcomes and corrective actions required addressing the concern or problem. The training program determines the communication method (worksheet, test, verbal communication, or other means deemed appropriate) and **whether the corrective procedures for these tasks are actually performed.**" We have to give the folks at NATEF credit. They understood that there were some time concerns in accomplishing all of these tasks and therefore they decided that for some tasks, analysis was more important than the remedial process. I intend to discuss the NATEF task list and its application to the various levels of education/training in future articles. It is my goal to clear up some of the massive confusion that exists or to at least cause instructors and advisory committees to think about how the task list is being applied to their programs.

ATech's primary goal in creating its troubleshooting Training series of products was to improve efficiency and increase the student's "experience age" as quickly as possible. There are many products in the series, but I want to focus on the 2815 - Starter, Battery, and Tester troubleshooting. Everyone knows how to troubleshoot a simple starter circuit, right? But how does a teacher create 47 faults quickly that will truly challenge not only students but even advanced technicians? Everything from rusty chassis connections to "chattering" relays are included. Need to evaluate the battery in the 2815 vehicle? A battery load tester is included in the software! It is connected using the same procedure as on the vehicle and allows adjustable current loads. Let's examine the learning experience in the



# You Teach, Why do Students not Learn? Part V cont'd

“chattering” relay fault of the 2815. The relay chatter is slowed to about once per second to allow the student to see the voltage measurements for each condition -closed and open contacts. When designing learning activities, it is often essential to reduce the speed of operation to effectively illustrate what is actually happening. For most people outside of education/training and most new instructors, “if it ain’t exactly like the car, it ain’t real”. There are thousands of examples where “real” is neither an effective, efficient, or safe learning environment. But that is another topic - back to our circuit. In figure 1, with the relay in the closed part of the chatter cycle, the voltage measured at the feed point for the solenoid is 12.6 volts. Our measurement is made from the battery negative post; so why doesn’t the solenoid activate? We obviously need more information. Figure 2 shows the relay and the voltage measurement in the open part of the chatter cycle. Something is really messed up! How can there be a voltage at the solenoid feed point (10) when the relay is open?!

From an instructional design standpoint, these voltage measurements are one of the primary reasons for slowing the chatter frequency. If the chatter frequency was 10 times per second and the voltages for closed were 12.6 and open at 1.15, what would the

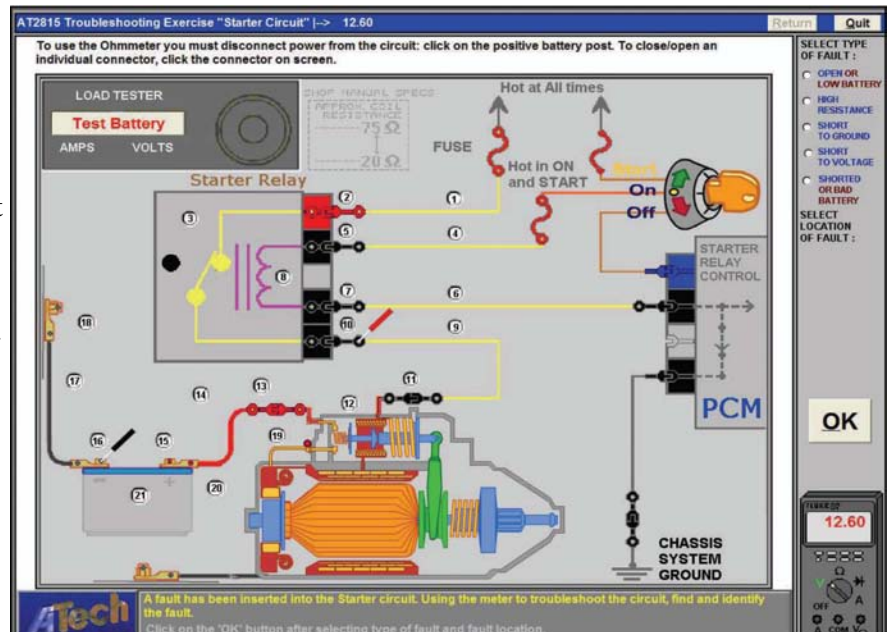

Figure 1

windings provide parallel paths for current flow. Is there another parallel path? Yes, the PCM starter relay control switch is also chassis grounded. As shown in figure 2, the PCM switch is still closed with the relay contacts open on the open part of the chatter cycle. Therefore we would have some current flow from the battery negative post through the ground cable, through the PCM starter switch chassis ground, through the relay coil to the positive post of the battery. A simple series circuit being fed from a parallel branch at the chassis (electron flow theory).

How can we determine if there is current flow through the starter solenoid branch? As shown in figure 3, measure the voltage drop across the solenoid assembly from the chassis ground cable to the relay (10). The meter indicates 0 volts. You could also measure from the negative battery post to the chassis cable at the starter and compare that to the voltage measured at the relay (10). Both points should measure 1.15 volts which results in a 0 voltage drop.

The same points measured in figure 4 on the closed part of the chatter cycle indicates a voltage drop of 3.50 volts indicating current flow through the branch.

There are many more measurements that can be made, but what we have so far should raise suspicion of the ground circuit. In figure 5, the voltage drop on the battery chassis connection is measured during the relay closed part of the chatter cycle giving 9.10 volts. Figure 6 shows the ohmmeter measurement of 5 ms at the negative battery post. The problem is an oxidized batterble clamp connection resulting in a high resistance. Figure 7 shows the battery load tester in operation.

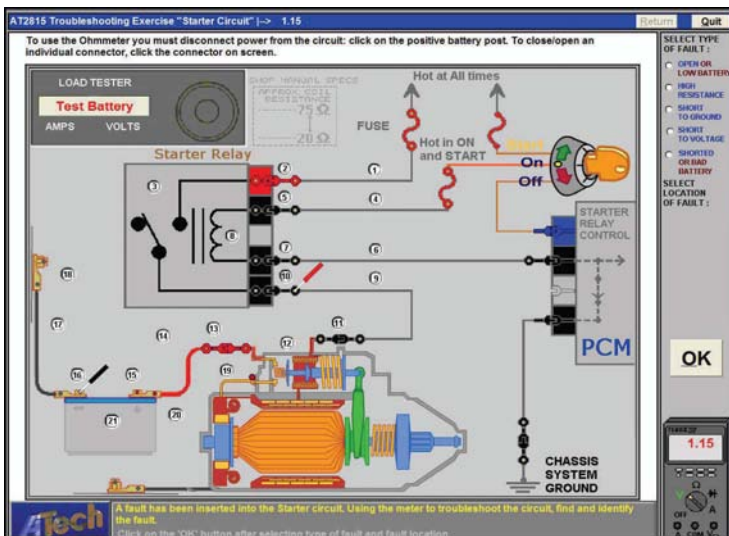

Figure 2

voltmeter actually read Assuming it was a 50% duty cycle, it would read 6.875 volts. How are you going to explain that to the student in the “real” world? In our slowed down circuit, they can measure the voltage extremes and calculate the average. The instructor is therefore more efficient - the student learns considerably more in a much shorter period of time! Back to the circuit.

How is it possible to have 1.15 volts at point (10) in the circuit when the relay is open? Look at the starter motor/sole-noid assembly. Both devices are frame grounded through the ground cable to the chassis. The solenoid coil and the starter motor

# You Teach, Why do Students not Learn? Part V cont'd

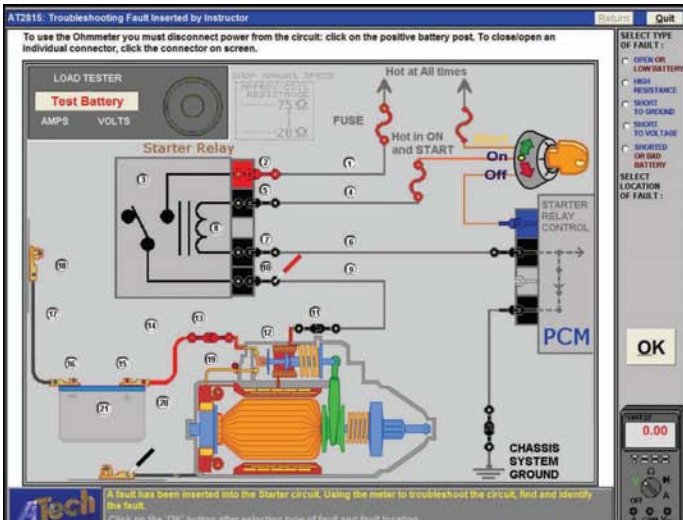

Figure 3

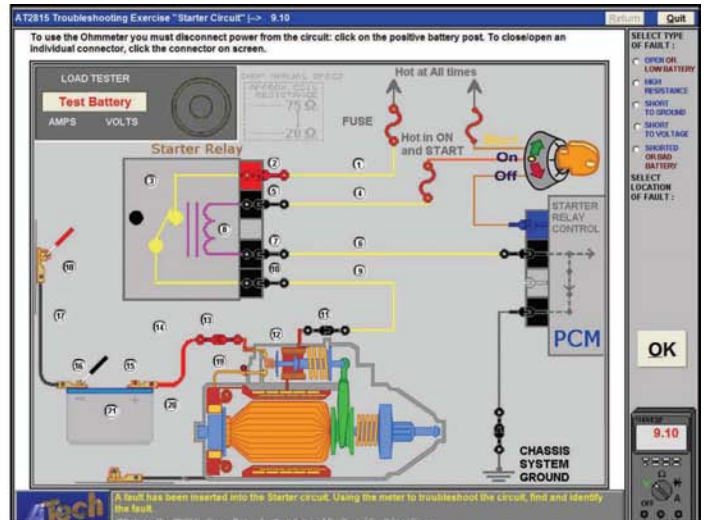

Figure 5

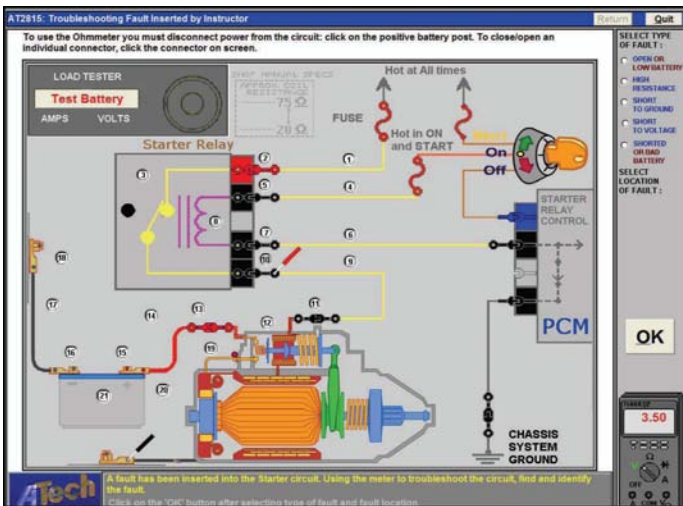

Figure 4

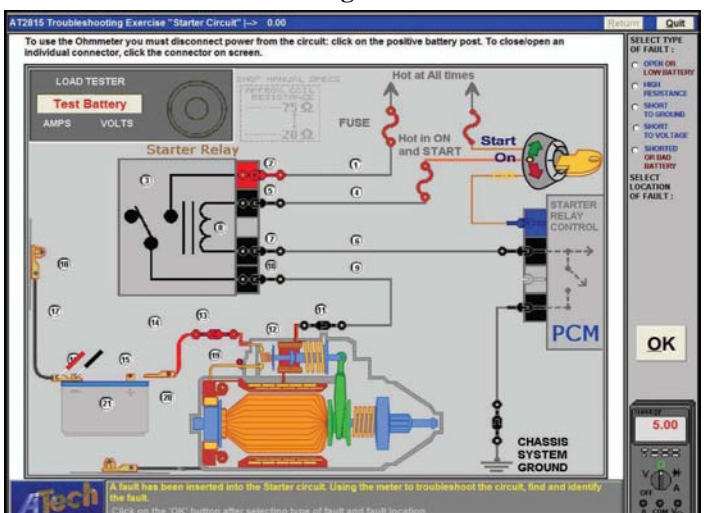

Figure 6

Want to cause the student to apply logic, mathematics and Ohm's Law?

1. Have the student calculate why the meter reads 1.15 volts in figure 2.
2. Ask the student to do the same calculation as in question 1 but do not sue the current value. Hint - it has something to do with 1/11.
3. Perform the same calculations with the voltage measured in figure 4.

Remember this is the "training" level. The "advanced" level is still ahead. Forty seven faults in "training" level and forty seven faults in "advanced" level. Ninety four faults total!

Is understanding these circuits important? There is a major trucking company which gave up on their technicians troubleshooting starting and charging circuits. They found it less expensive to have them replace everything when there was a problem! The tech's "troubleshooting" took large amounts of time and then they replaced everything anyway!

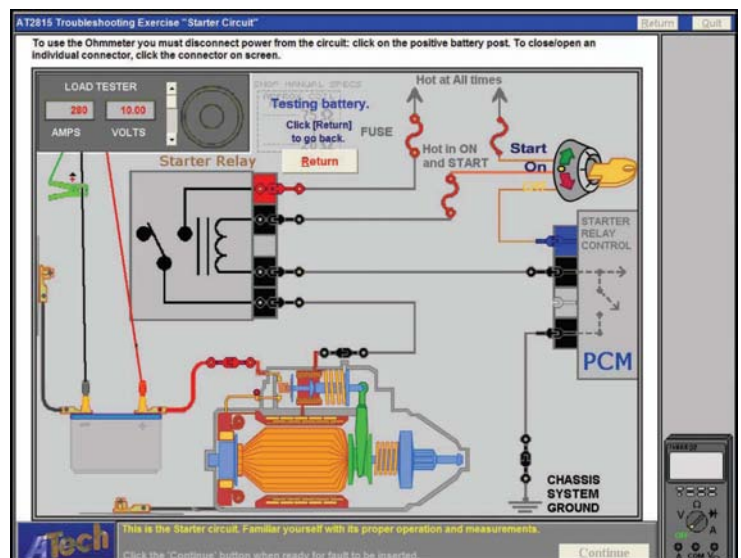

Figure 7

**Starter Circuits are simple, right?**

# You Teach, Why Do Students Not Learn, VI

How do you implement the “Discovery” approach into your program? What will surprise many instructors is that they are very likely to be using the Discovery instruction method already. After you read this article, take a look around your program. I am sure you will find areas that you have been using these techniques because you have subconsciously found them to be effective.

Let’s look at one of the more subtle techniques - “Discovery by Association” used in the virtual S.E.T. program. Figure 1 is a screen from Stage 2. The parts have been placed from the toolbox on the screen but they have not been connected yet. An instructor could spend hours lecturing about the information on this one screen. For example, the symbols in the schematic box in the lower right corner—light bulbs, transistors, switches, potentiometers, fuses, ground, and supply. The virtual S.E.T. program is designed to make maximum use of the “Discovery by Association” technique.

Examples:

Students drag the pictorials of the parts in the schematic from the toolbox to the wiring area. They identify the appropriate pictorials for the schematic representations by the module number. This one simple process causes the student to associate the physical part with the schematic symbol with no lecture. Plus it is an interactive sequence. One point that cannot be overemphasized is the importance of causing the student to actually do something. Ask yourself these questions, “Do I like sitting in a 2 hour lecture?”, “What were the most informative and enjoyable learning experiences I have had?”. The answer to the first question is NO. For the second question, it will typically be the ones that were interactive; caused you to actually do something. Time flies by when the students are absorbed in the process.

In Figure 2, as the potentiometer is adjusted with the slide bar, both the symbol in the schematic and the associated pictorial move in direct relationship. Also the light bulb varies in brightness based on the potentiometer position. One of the major advantages of a properly designed computer based training program is the ability to demonstrate internal operation of devices. Compare this capability with the actual hardware S.E.T; when the student changes the potentiometer value in the hardware version, the light bulb changes brightness but there is no indication as to what caused the change. What takes place inside the potentiometer remains a mystery. Another example is the relay.

In Figure 3, the internal parts and operation of the relay are interactively illustrated. As the student operates the push button switch, the relay changes contacts and the door lock actuator extends and retracts. This is an excellent place to utilize another of the Discovery techniques - “Directed Experi-

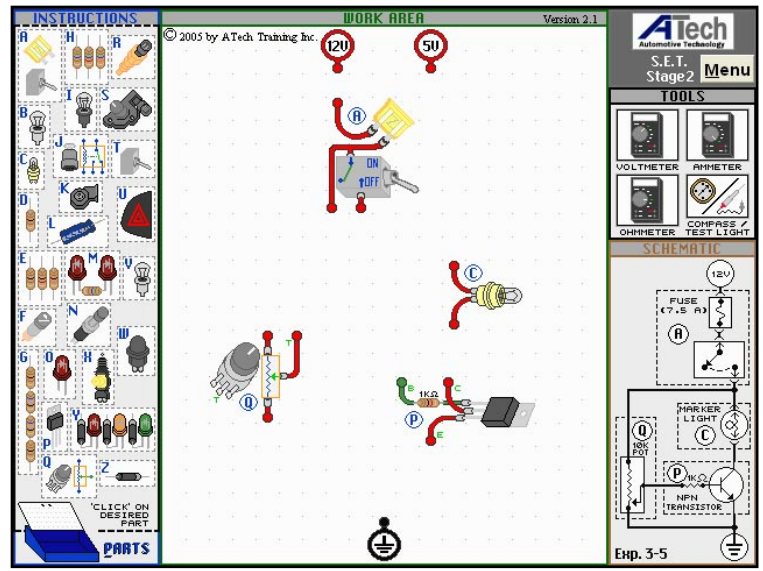

Figure 1

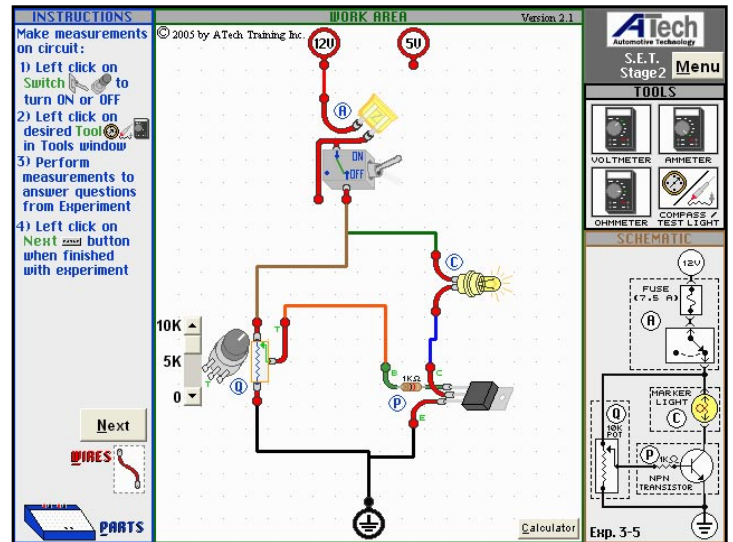

Figure 2

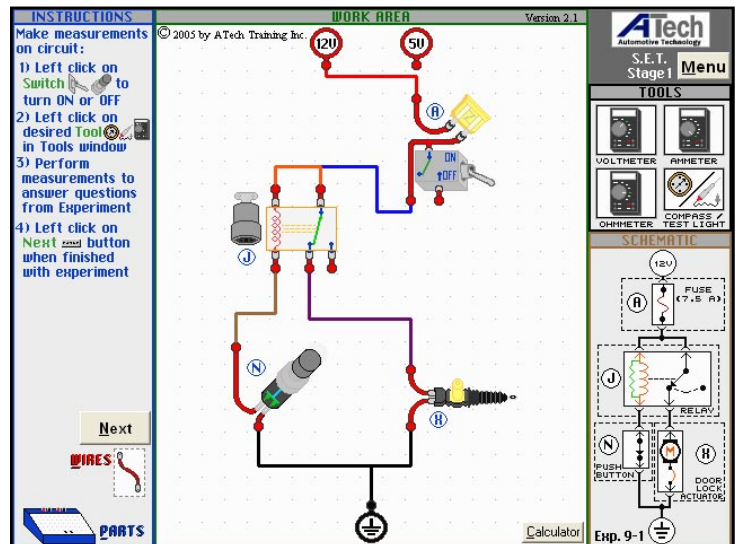

Figure 3

**A-Tech Training Inc.**

**A Veteran Owned and Operated American Company**

## You Teach, Why do Students Not Learn? Part VI cont'd

mentation". While the student is working on this activity, give them a typical automotive relay that has had the cover removed. Have them identify the actual internal pieces of the relay that correspond to the pieces in the illustration. They can physically operate the "pole" (moving contact assembly) and identify the normally open and normally closed contacts. Relays have always been a major difficulty for beginning students. Use this approach and 90% of the confusion and misunderstanding disappears.

The relationship between short term and long term fuel trim has always been a problem for students and technicians. In Figure 4 there is a large amount of information about the relationship between short term fuel trim, long term fuel trim, injector pulse width, and the fuel control oxygen sensor. How long would it take to lecture an understanding of short and long term fuel trim to a group of students? For the majority of

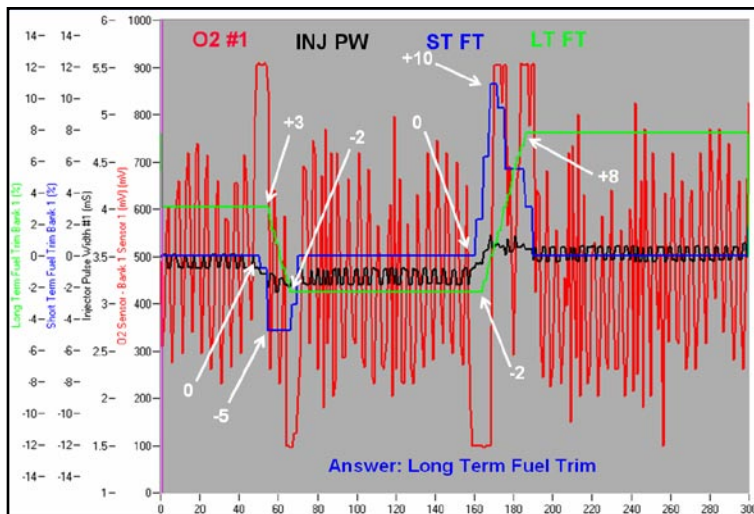

Figure 4

students, it will never happen.

Through the "Directed Experimentation" technique of the "Discovery" instruction method, the time and effort required can be dramatically reduced. Figure 5 shows the oxygen sensor / fuel trim section of the ATech OBDII training system. Have the student connect any available scan tool to the trainer and set it to show short and long term fuel trim. The fuel trim potentiometer on the panel (Figure 5) controls the upstream oxygen sensor. Ask the student to use the potentiometer and adjust the upstream (fuel control) oxygen sensor to produce a short term fuel trim of +10%. In the process of accomplishing this, the student will watch the long term fuel trim take away the short term fuel trim he attempts to add in. Once long term reaches its limit of approximately +25% then they will be able to adjust the short term to the requested +10%. The next step would be to have them adjust it to -10%. Finally, ask them to describe the relationship. This one simple activity will allow the student to learn more about the short term - long term fuel trim relationship than hours of other methods.

How could we make the fuel trim activity in the above paragraph even better? By making it more intuitive for the student. For our purposes, intuitive means easier to understand

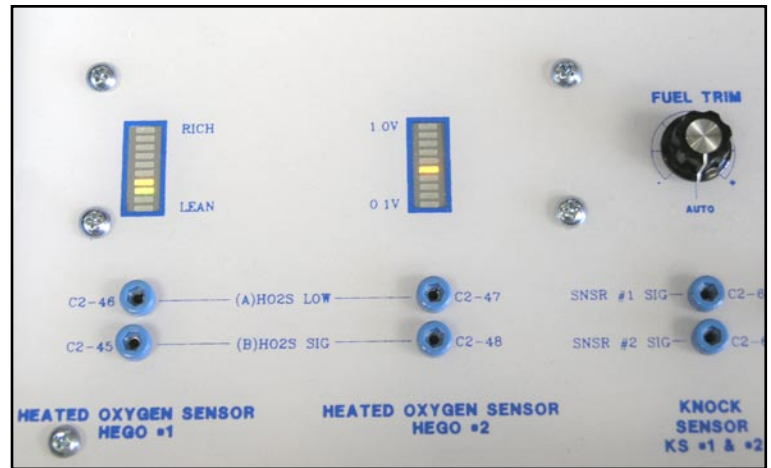

Figure 5

because of past experience. Typical scan tools display short and long term fuel trim as numbers as shown in Figure 6. Think about how difficult it is to monitor two number displays that are constantly changing and determine a relationship!

Why are most speedometer and tachometer displays analog? So you don't have to read them! All it requires is a glance to see the indicator position after we learn the scale. For example, if the indicator is pointing to the middle of the display, it is approximately 60 MPH. We don't need to know the exact value. A digital speed display would require you to actually read the numbers!

The point is that students

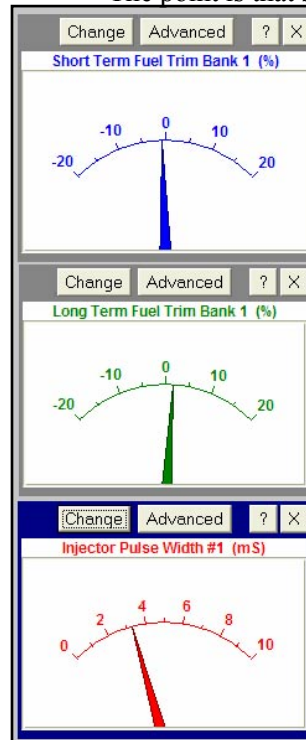
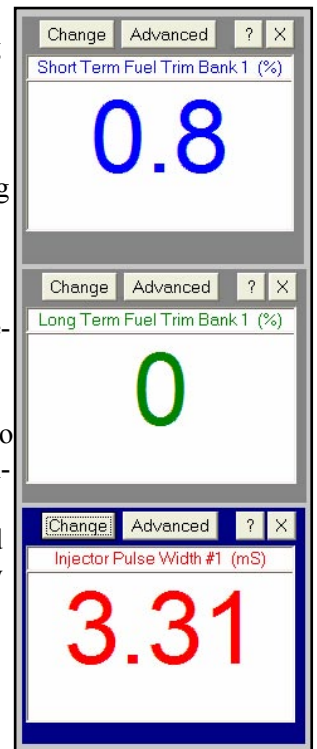

Figure 6

are much more familiar with analog gauges. If you have an AutoTap scan tool you can set up the gauges as shown on the left. These allow the student to see the amount and direction of the fuel trim values much easier. They can clearly see long term absorbing and reducing short term. We are using their experience with analog gauges to make the activity more intuitive for them.

While we have used the associated ATech training systems in our illustrations, there are many ways to apply these techniques to whatever you are using for training. All it requires is to change the way you think about the education / training process.



# CHANGES AND RESULTS of You Teach, Why do Students not Learn?

For fifteen years I taught my Automotive Technology course using the same basic schedule. That schedule was a modified version borrowed from one of Missouri's best instructors. It was a good model based on educational research that broke the subject areas into 3-week sections (research has shown that student interest and retention drop quickly after more than a few weeks on any one subject). I started each year with Electrical/Electronics in the traditional format teaching electron theory in the classroom and building on each lesson. Because most systems on today's vehicles use a least some electrical components, it is very important for the students to have good electrical service skills. Electrical/Electronics has always been the most difficult topic for my students and frustrating for me. Each year I tried harder (more time in the classroom) to improve the students' performance. I bought PowerPoint presentations, videos and DVDs; all offered little improvement. After reading Fred's article "You Teach, Why do Students not Learn?" in Dec 04, I decided to make changes in my program's schedule and delivery. I talked to a lot of former students and several area instructors about how to develop a plan that would engage the students and reduce lecture time.

Instead of spending weeks teaching students the names of tools and equipment or how electrons flow in an electrical circuit, the new plan puts the tools in the students' hands from day one.

Beginning with the 2005-2006 school year, we started with Engine Performance; students were assigned engines supplied by a local salvage yard. During the first two weeks of school the students disassemble, clean and measure their engines' components. They also learn about shop safety and engine diagnosis. Each student was asked to give a report on their engine that covered the make, model, type and size of the engine as well as internal condition.

In the past, I would lay tools on the lab floor and place a number on each. The students would then use tool catalogs and their texts to identify each of the tools. I would then talk about most of the tools and demonstrate how each was used. This lesson was followed by a test. It was not uncommon for some students to score only 40 percent. In 2005-2006 the students took the same tool test after using the tools to disassemble their engine and the average score was above 90 percent.

To improve Electrical/Electronic knowledge and diagnostic skills, I now start the students using Digital Multi Meters to test electrical systems. The students may use the meter manuals and electrical service information. It is amazing how quickly most of the students learn in this manner. The students are asked to share information and to help each other. After the students have learned to use the meters to diagnose common automotive electrical circuits, we then cover the Electron theory in a classroom setting. Test scores and skills are much improved

For the 2005-2006 school year, I have applied what was learned in Engine Performance and Electrical/Electronics to all subject areas. The student's knowledge level and skills are both improved. Just as important, there have been very few students that have struggled or lost interest.

Technical teachers are often asked to teach academic topics like math or science in an applied setting and have been successful. So why have we tried to teach automotive topics using academic methods? The key is to create a need to learn by the students and to give them the materials to discover the answers for themselves.

Robin Ferguson  
Kirksville Area Technical Center  
Kirksville, MO

---

## First Two Weeks - Automotive Technology - Kirksville

### Module: Introduction to Automotive Technology Engine Performance

#### Day 1

\*UVI L1 Personal Protective Clothing & Equipment  
Student Pretest

\*\*Task VIII A5 Inspect engine assembly for fuel, oil, Coolant, and other leaks; determine necessary action.  
Lab: Assign tool boxes.

#### Day 2

UVI L2 Fires and Fire Extinguishers  
Task VIII A2 Identify and interpret engine performance concern; determine necessary action.  
Lab: Select teams and assign engine.  
Inventory tool boxes.

#### Day 3

UVI L3 Federal and State Agency Regulations

Task VIII A6 Diagnose abnormal engine noise or vibration concerns; determine necessary action.

Lab: Mount engine on stands – Identify engine type, size, make, and model.

#### Day 4

Test UVI Safety Clothing and Equipment  
Task VIII A7 Diagnose abnormal exhaust, color, odor, and sound; determine necessary action.  
Lab: Begin engine disassembly. Remove covers and pans.

#### Day 5

UVI L1 Solvent  
UVI L2 Soaps and Cleaning Solutions  
Task VIII A18 Verify correct camshaft timing.  
Lab: Engine disassembly; remove manifolds

# You Teach, Why Do Students Not Learn , Part VII

What is the ultimate goal of teaching electricity to automotive students? It is not learning Ohm's Law or how to use a multimeter. It is to develop **troubleshooting skill**. Therefore, troubleshooting practice should not be the final 30 minutes of a 4 week program. It should start in the very first sections and be an integral part of every section. If incorporated correctly, it will help the student gain understanding of the circuit relationships.

In a similar manner, what is the ultimate goal of your automotive program? It is not to perform a specific number of NATEF tasks or complete all exercises in a textbook. It is to have the student obtain a job or to prepare for further education? Actually it should be both and that applies to secondary and post secondary programs.



“Teach the student, not the subject” is one of my statements that has caused considerable discussion. Almost all training programs are structured to teach the subject. The NATEF task list emphasizes teaching the subject. Every textbook is structured to teach the subject. How can all of these be wrong?

Teaching the student requires the program to be student centered as opposed to subject centered. Subject centered teaching is the academic way and has failed in educating most students for the last 100 years. Automotive programs have a unique advantage. They are application oriented meaning they are centered around the vehicle. Now, if the program can be made “student centered” it will be the best of both worlds.

What does it mean to have the program “student centered”? It means that the program is structured to consider the best interests of the student at all times. For example, a new student enters the program, six weeks later his father dies leaving him to help support the family. If the program is “student centered” he would have a marketable skill at the 3 to 4 week point! How is this possible? By rearranging the tasks in the program to be progressive in skill level.



This is where your program's advisory committee can be a tremendous help. What are their shop's entry level positions and chain of advancement? In other words, if they

hired an inexperienced person, what jobs would be available to that person? What would be the next jobs available as the person progressed? This should be exactly how your school program is organized. The difference is the school program should provide structured experiences to give the student the most training in the shortest period of time.

But even after the student has been through your program, what job levels are they initially given at the shops? Every incoming employee will be run through an in-house evaluation process at the shop. They will be given low level jobs until management gains confidence in them. What is the difference between one of your graduates and someone off the street? Your graduate should go through the evaluation process and up the job levels much faster than the person off the street.

How do you change to a “student centered” program? Let's assume that one of the first jobs in the shop is tire rotation or oil changes. Look through the entire NATEF task list and find those tasks that fit those two jobs. Arrange them in the first part of your program intermingled with all of the safety and hazardous material requirements. Not only does this make the beginning of your program much more interesting but it breaks up the monotony of the safety and hazardous material sections. How does NATEF feel about rearranging the task list?



**“For purposes of program design/development, it does not matter to NATEF whether classes are taught in a linear fashion (all of brakes; all of suspension & steering, etc.) or in another way which moves across the areas and puts logical tasks together.” Mary Hutchinson, Past Executive Director.**

There is no substitute for job placement of students. Both school and state administrators want job placement, they don't care whether the student has completed all of the NATEF tasks. How long would a program continue to exist if every student completed the entire program, but no one obtained a job? After job placement, the next best result is “continuing education”.

You have put a lot of effort into your present curriculum. Why should you change? First, you are not changing your entire program at one time. That would be virtually impossible. As stated in earlier newsletters, start with the one section that will have the most impact. What is the most critical section of your program? No doubt it is the beginning portion. It is where you lose most of your students and where student “attitude” is established.

## You Teach, Part VII, cont'd

What will you gain from the change? Student interest in the program will be high resulting in less discipline problems and drop-outs. Word will circulate around the school/ district that this is a "student centered" program resulting in easier student recruitment. Other school faculty members will start sending their own children to your program. Administrators will start bringing visitors to see your program. It can happen!

One other very important thing you as a teacher gain is freedom. Each section that you change will allow more freedom for you. Freedom to help the students who really need the help. Freedom to evaluate your program and make it better. Wouldn't it be great to look forward to coming to work most days? Sounds too good to be true and it will not happen instantly. It takes work and dedication.

Today, one major goal of every automotive program is to have the student learn how to teach themselves. It is recognized that with the amount of future change in the field, they will not have the extra time to learn most new items in a school setting. This goal is a perfect fit into our student centered "Discovery" based program. How do you teach a student to teach themselves? It certainly isn't by giving them assignments to research projects or cruise the internet looking for information. Most of your students have already experienced those processes in the "academic" programs and how well do they teach themselves when they come to your program?

"Discovery" teaching requires the student to start the self-teaching process. "Self Teaching" is personal "Discovery". Without ready answers, reaching a conclusion requires analysis and evaluation. The instructor enhances the process by answering questions with the questions the student should have asked himself. But like any other learning process it requires small steps and practice.

The quickest way to failure in this process is to tell the students you are trying a new teaching method with the purpose of developing their ability to "self teach". This is the standard academic approach; to tell the students the objective before you start the program. In this case, the students will immediately "shut down" or actively rebel. Think about their past experiences. How many times have they been told in the academic education experience, "This will benefit you in the future"? That is the academic justification for all the math and science classes.

Forget that nonsense and structure your program to create interactive "Discovery" based learning experiences. Give the students the opportunity to develop their self teaching skills without realizing what they are doing.

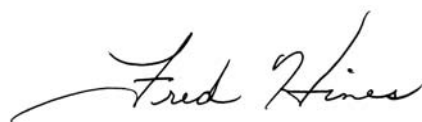
A handwritten signature in cursive script that reads "Fred Hines". The signature is written in black ink and is positioned at the bottom right of the page.